

# INVENTRONICS

EDC-075S105ST-000x

Rev. C

- K? ; (' fl
- O' %fl
- 1 +bM -bM
- 
- : @jj @
- 
- Ł
- @--
- 



< : \$ . , J ( ' , JK\$ ' ' x . , N @--

( + ' \$\* ' , M&c



--	--	--	--	--	--	--

( 1) ) ' \$ ) + ' M&c  
 ) ( ' ' \$\* ' , M&c ( ' ' \$ ( + ' M&c  
 \* )) ' M&c ( ' ' fl

# INVENTRONICS

EDC-075S105ST-000x

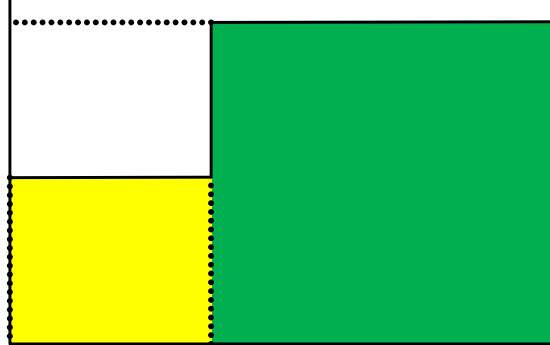
Rev. C



				? d
		-		

# INVENTRONICS

EDC-075S105ST-000x

Rev. C

		°		°

: iee OCad g OP\$>)

				(' fl ), ) %fl
				))' Mac ), /' fl ŽD @ \$ ?; 9B\$ (. =ž
				))' Mac /' fl , , °:
			°	'
ŽC × N × ? ž				, %- × ) %) × ( %-
ŽC × N × ? ž				(( + × - + × * ) ( * ( × - + × * )

: iee OCad g OP\$>)

<b>EMI</b>	

EMI	
EMS	

( <D @

ž ž <D @

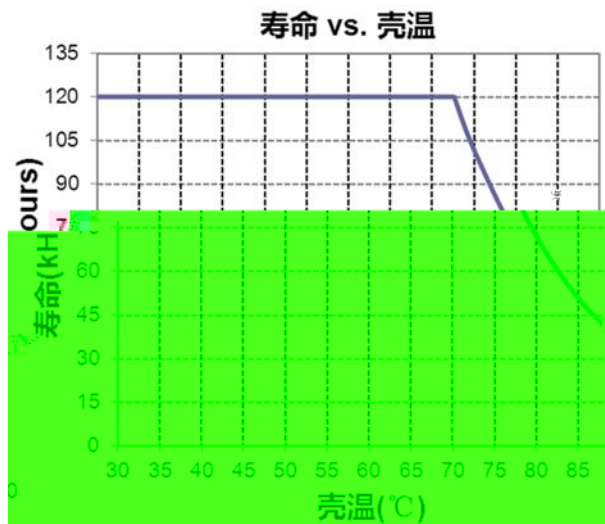

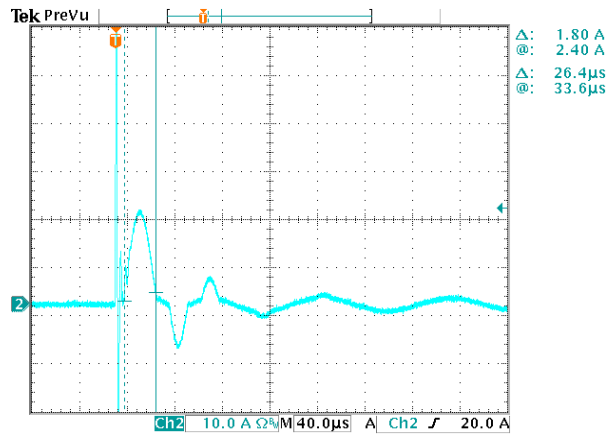

EDC-075S105ST( $I_o=1050\text{mA}$ )  
效率 vs. 输出电压

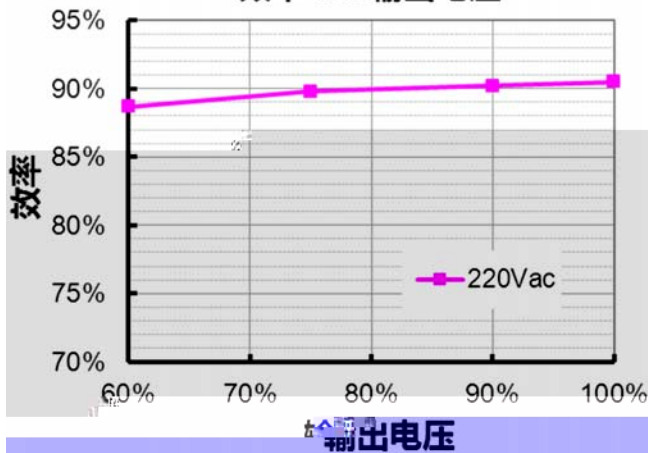

EDC-075S105ST-0004( $I_o=860\text{mA}$ )  
效率 vs. 输出电压

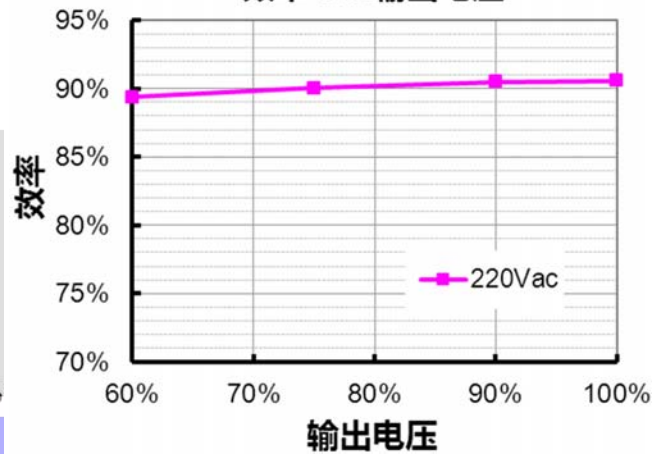

EDC-075S105ST-0007( $I_o=700\text{mA}$ )  
效率 vs. 输出电压

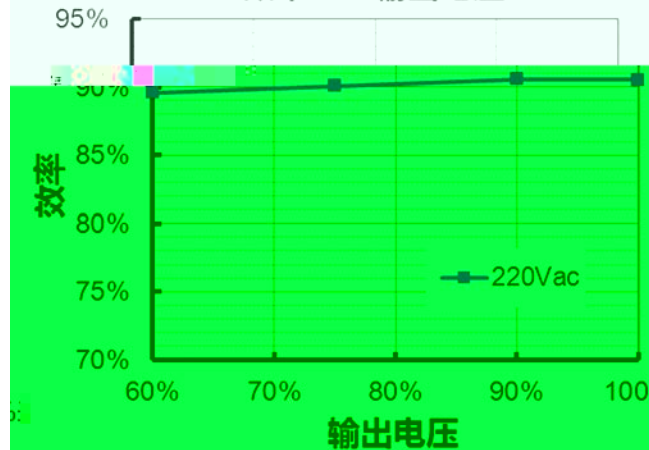

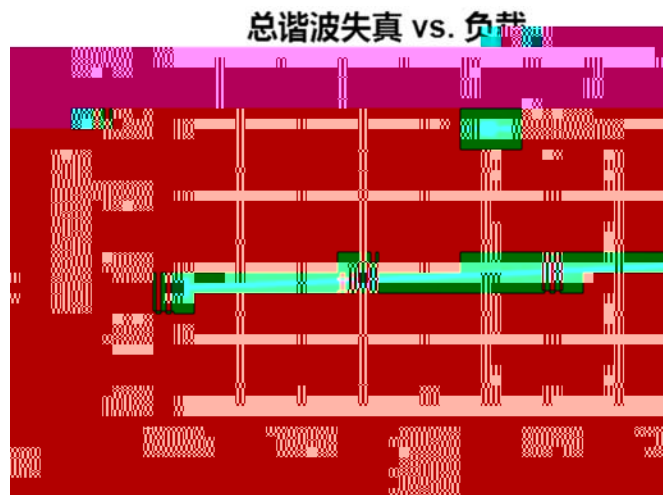
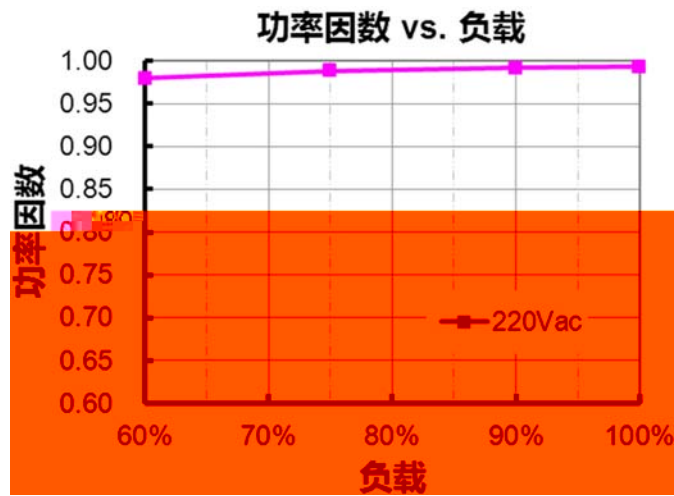

# INVENTRONICS

EDC-075S105ST-000x

Rev. C

---



9



# INVENTRONICS

EDC-075S105ST-000x

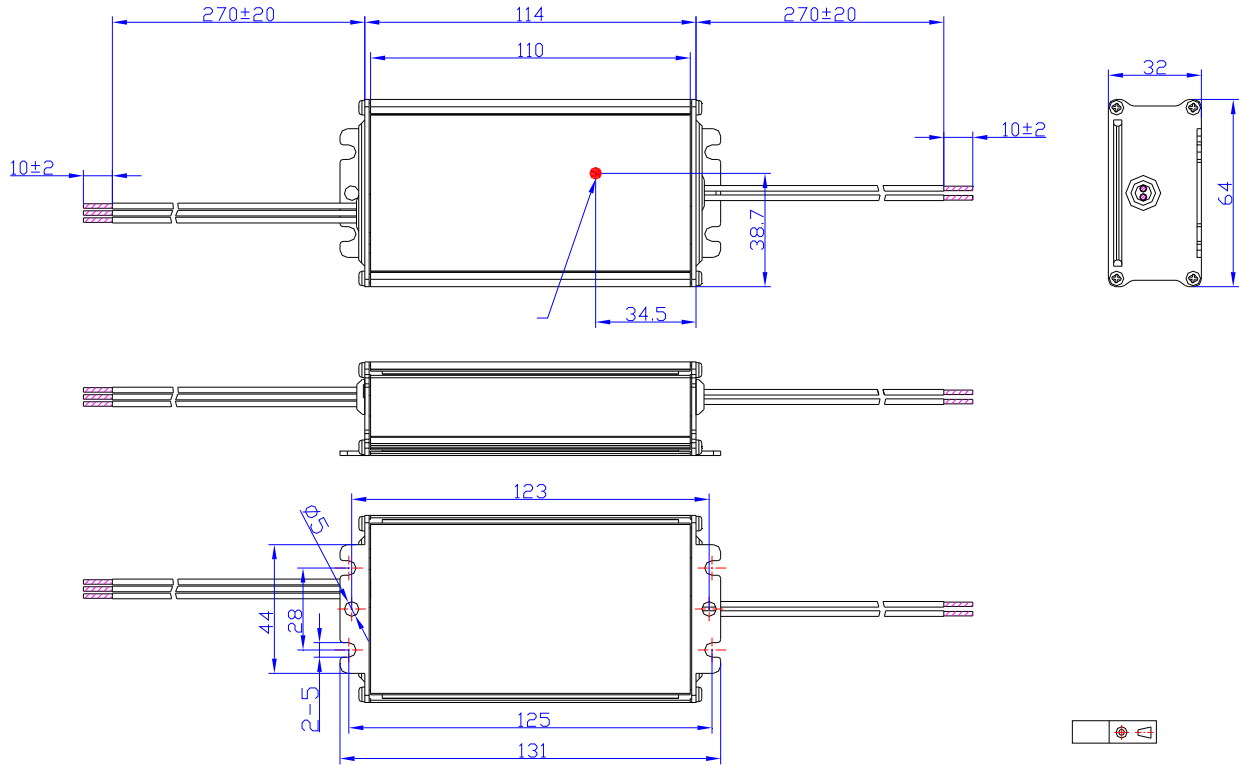
Rev. C



I f? J )' ((&, &L

<L )' (, &/- \*



X

**EDC-075S105ST-000x**

*Rev. C*

---